

THIS DRAWING IS UNPUBLISHED. RELEASED FOR PUBLICATION
 © COPYRIGHT BY TYCO ELECTRONICS CORPORATION. ALL RIGHTS RESERVED.

LOC	DIST	REVISIONS					
AJ	00	P	LTR	DESCRIPTION	DATE	DWN	APVD
		B		REV PER ECO 07-004710	3/2/2007	DW	KW

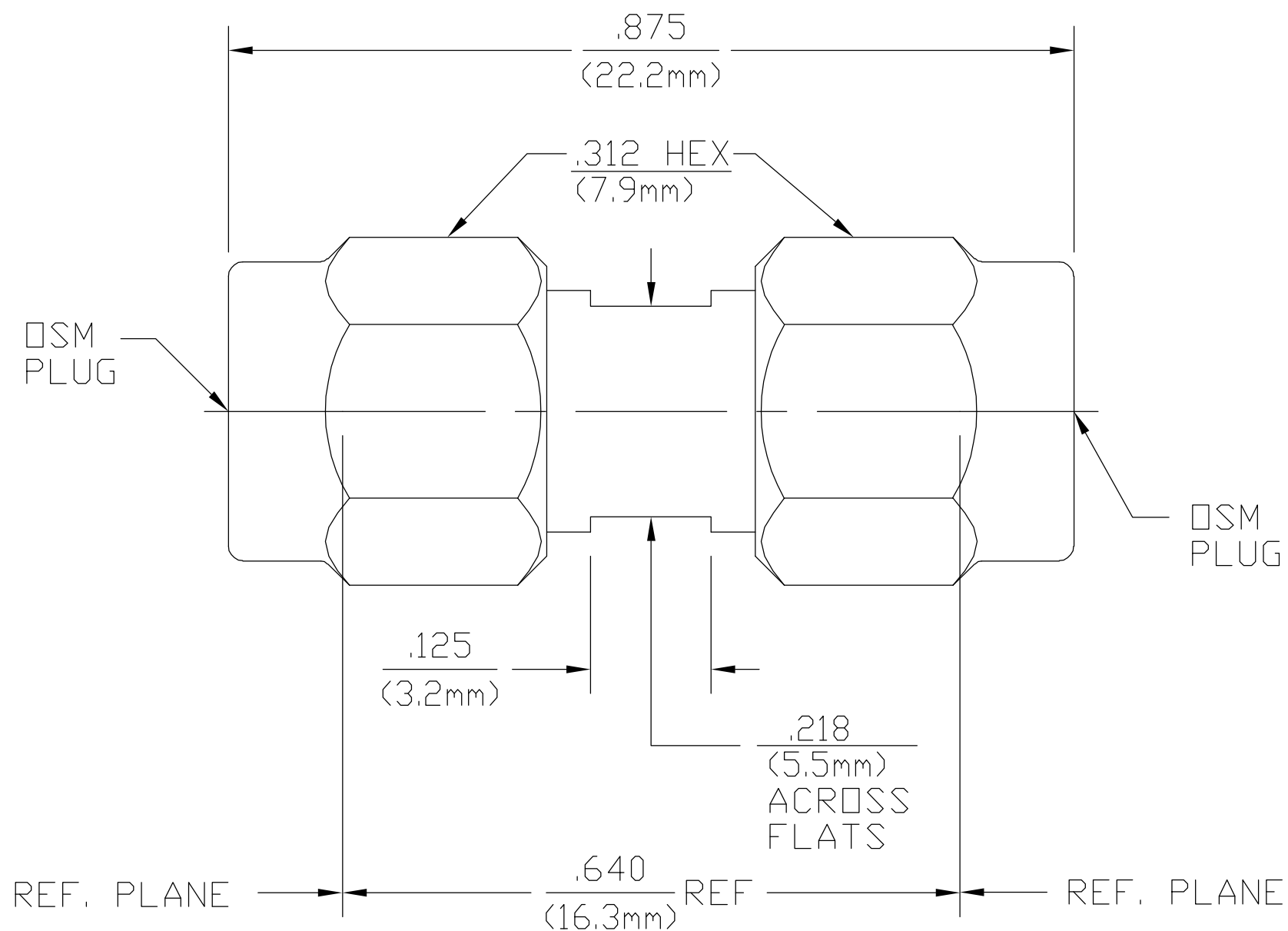

ELECTRICAL	MECHANICAL	ENVIRONMENTAL
Nominal Impedance (Ohms) <u>50</u>	Interface Dimensions MIL-STD-348A	TEMPERATURE RATING <u>-65°C TO 165°C</u>
Frequency Range (GHz) <u>DC to 18.0</u>	FIG 310.1	Vibration - MIL-STD-202, Method 204, Condition D
Volt Rating (VRMS MAX) <u>335</u>	Recommended Mating	Shock - MIL-STD-202, Method 213, Condition I
VSWR <u>1.05 + .005f(GHz) MAX</u>	Torque <u>7.0 to 10.0 In/Lbs</u>	Thermal shock MIL-STD-202, Method 107 Test Condition C
Insertion Loss (dB MAX) <u>.06 √f(GHz)</u>	Connector Engagement	Moisture Resistance - MIL-STD-202, Method 106, except Step 7b
RF Leakage <u>-[90-f(GHz)]</u>	<u>2.0 In/Lbs MAX</u>	(Vibration) shall be omitted
Corona, 70,000 Ft (VRMS MIN) <u>250</u>	Center Contact Captivation	Corrosion - MIL-STD-202, Method 101, Condition B, 5% salt spray
Dielectric Withstanding Voltage (VRMS MIN) <u>1500</u>	Axial <u>10 Lbs MIN</u>	
Contact Resistance (Milliohms MAX)	Radial <u>N/A</u>	
Center Contact <u>4.0</u>	Weight (Grams) <u>TBD</u>	
Outer Contact <u>2.0</u>		
RF High Potential (VRMS MIN @ 5 MHz) <u>670</u>		
I.R.(Megohms) <u>10,000</u>		

HOUSING COUPLING NUT	STAINLESS STEEL PER ASTM-A484 AND ASTM-A582, TYPE 303	PASSIVATE PER QQ-P-35
DIELECTRIC	PTFE FLUOROCARBON PER ASTM-D-1457	N/A
CENTER CONTACT	BERYLLIUM COPPER PER ASTM B 196, ALLOY C17300, CONDITION H OR BRASS PER ASTM-B-16	GOLD PLATE PER MIL-G-45204
RETAINING RING	BERYLLIUM COPPER PER ASTM B 194, ALLOY C17200, CONDITION H	N/A
GASKET	SILICONE RUBBER PER ZZ-R-765	N/A
COMPONENT	MATERIAL	FINISH

THIS DRAWING IS A CONTROLLED DOCUMENT.

DWN	B.M.EDWARDS	8/31/90
CHK	K.MAHER	9/4/90
APVD	S.TM	9/5/90

tyco Electronics Tyco Electronics Corporation
Harrisburg, PA 17105-3608

NAME: OSM PLUG TO PLUG ADAPTER

SIZE	CAGE CODE	DRAWING NO	RESTRICTED TO
A2	00779	C=1053640	-

CUSTOMER DRAWING SCALE 5:1 SHEET 1 of 1 REV B